

Capital Program Management
Construction Scheduling
Standard Coding and Procedures
For Designers and Contractors
Manual

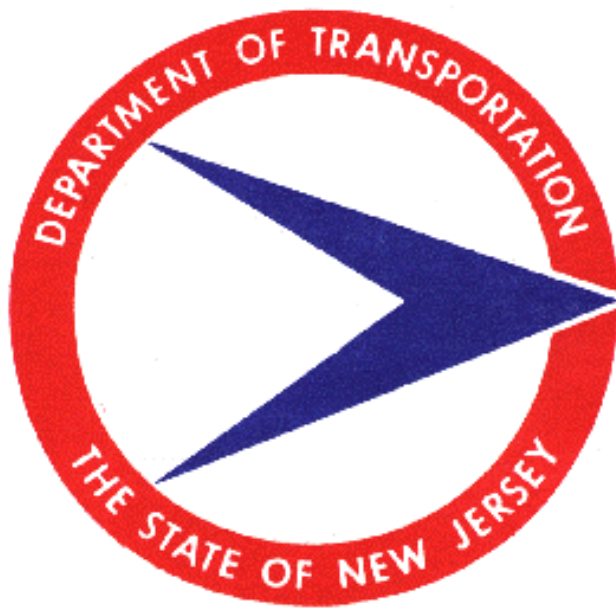

BDC 01T-5
2001

Prepared by: NJDOT
Quality Management Services
Construction Scheduling and Assessment Section

Table of Contents

A.	<u>Introduction</u>	<u>2</u>
B.	<u>Scheduling Software</u>	<u>2</u>
I.	<u>Construction Schedules</u>	<u>3</u>
II.	<u>Equivalent Software</u>	<u>3</u>
C.	<u>Best Practices</u>	<u>4</u>
D.	<u>Standard Coding</u>	<u>4</u>
I.	<u>Development of Progress Schedules</u>	<u>5</u>
II.	<u>Design/Construction Template (WBS)</u>	<u>6</u>
III.	<u>Work Breakdown Structure (WBS)</u>	<u>7</u>
IV.	<u>Standard Activity Codes</u>	<u>11</u>
E.	<u>Standard Factors</u>	<u>27</u>
F.	<u>Level of Detail Required on a Progress Schedule</u>	<u>28</u>
G.	<u>Designer Contract Time Determination</u>	<u>28</u>
I.	<u>Design Submission</u>	<u>29</u>
II.	<u>Final Design Submission</u>	<u>30</u>
III.	<u>Designer Standard Naming of Projects</u>	<u>30</u>
IV.	<u>Multi-Year Funding</u>	<u>31</u>
V.	<u>Determine Start of Construction</u>	<u>31</u>
VI.	<u>Production Rates</u>	<u>32</u>
a.	<u>Table A Roadway Items (English)</u>	<u>32</u>
b.	<u>Table B Bridge Items (English)</u>	<u>34</u>
c.	<u>Table C Bridge Items One Span (English)</u>	<u>35</u>
d.	<u>Table D Bridge Items Two Span (English)</u>	<u>36</u>
e.	<u>Table A.1 Roadway Items (Metric)</u>	<u>37</u>
f.	<u>Table B.1 Bridge Items (Metric)</u>	<u>39</u>
g.	<u>Table C.1 Bridge Items One Span (Metric)</u>	<u>40</u>
h.	<u>Table D.1 Bridge Items Two Span (Metric)</u>	<u>41</u>
VII.	<u>Acceleration of Contract Schedules</u>	<u>42</u>
a.	<u>Increased Production Rates</u>	<u>43</u>
b.	<u>Incentive/Disincentive</u>	<u>43</u>
c.	<u>A + B Bidding</u>	<u>44</u>
d.	<u>Lane Rental</u>	<u>45</u>
VIII.	<u>Designer Narrative</u>	<u>46</u>
H.	<u>Contractor Procedure</u>	<u>47</u>
I.	<u>Contractor Standard Naming of Projects</u>	<u>47</u>
Appendix		
A.	<u>Definitions</u>	<u>48</u>
B.	<u>Time Impact Evaluation Form</u>	<u>50</u>
C.	<u>Utility Companies by Area</u>	<u>51</u>
D.	<u>NJDOT Request for Trainees Memo</u>	<u>54</u>
E.	<u>General Workday Chart (Contract Time Determination only)</u>	<u>57</u>
F.	<u>Procedure for utilizing the Construction Scheduling Template</u>	<u>58</u>

A. Introduction

Scheduling of a construction project is more important today than ever before. Most construction projects now involve the reconstruction of existing highways, which means that traffic will be disrupted. It is important that Designers and Contractors understand that work must be planned and executed efficiently to minimize these disruptions.

The Department has developed, with the Consultant and Construction industries, this manual to standardize construction scheduling for Designers and Contractors. Members of the team that developed this manual were:

Kevin Rittenberry	Division of Law and Public Safety DAG
Randy Prescott	FHWA
David Hawk	FHWA
Richard Forman	AGC/NJAPA
Len DePinto	Railroad Construction
Jack Tobin	PKF Mark-III
Don Goldberg	Goodkind & O’Dea
Rod Pello	Parson’s Transportation
Stacie Davis	Stacie A. Davis, P.E., PC
Tim Ronan	Baker
Frank Palise	NJDOT - Quality Management Services
Joe Fasanella	NJDOT - Quality Management Services
Jason Hahn	NJDOT - Quality Management Services
Stan Pierzhanowski	NJDOT - Quality Management Services
Mike DiPento	NJDOT - Bureau of Construction
Karl Ranganathan	NJDOT - Bureau of Construction
Sean Sheehy	NJDOT - Region North Construction
Jim Timpone	NJDOT - Region Central Construction
Charles Miller	NJDOT - Design Services
Dave Bizuga	NJDOT - Geometrics
Rick Hammer	NJDOT - Project Management
Chris Manz	NJDOT - Project Management
Andy Kuchtyak	NJDOT - Program Support
Mark Dietrich	NJDOT - Project Management
Emerson Misner (Chair)	NJDOT - Quality Management Services

We would like to thank members for their contribution and continued effort as this process evolves.

B. Scheduling Software

The New Jersey Department of Transportation, Capital Program Management has adopted the use of Primavera P3e software as the scheduling software to maintain a database of all Capital Program Management projects. This database will contain both a) Capital Program Management's schedule and budget for the entire design process for each project and b) The Designer's and Contractor's schedules for the proposed construction work required to complete the project. The Designer will begin development of a construction schedule starting with a preliminary schedule at Initial Design and reaching the final schedule at the Final Design

Submission. The Contractor will begin development of a construction schedule at the Award of Contract starting with the preliminary schedule and continue throughout the construction contract with the submission of a baseline schedule and monthly updates. This manual covers the construction scheduling portion from the initial design until the completion of construction.

B.I Construction Schedules

Generally, on projects with an estimated construction cost of less than \$5 million, a computer generated Critical Path Method (CPM) Progress Schedule shall be submitted on Primavera SureTrak software or other approved software that is compatible with Primavera P3e software. However, Primavera Project Planner P3 3.0 or approved equivalent software shall be utilized on projects that meet one of the following criteria:

- New Construction or Reconstruction/Rehabilitation projects that require staging plans or a specific sequence of construction
- Major utility relocations.
- Significant right-of-way impacts.
- Estimated duration of longer than one construction season.
- All projects over \$5 million construction cost

The specific software to be utilized on a particular project will be determined by Construction as part of the Final Scope Development process.

B.II Equivalent Software

Reference is made to Primavera products throughout this manual and also in the Specifications. It is understood that computer software technology is constantly changing and improving and as per Subsection 106.12 that Substitutes or "Or Equal" products are or may become available. To be approved as a Substitute or "Or Equal" the software must be completely compatible with the database that contains the Capital Program Management's design process schedule and budget as well as the construction scheduling from initial design through construction. The software shall be compatible with the hierarchy of the coding and able to import and export data within the NJDOT Capital Program Management's database without distortion of any coding or relationships contained in the database.

The Designer shall only utilize equivalent or compatible software, which has received written approval from the Department prior to their submittal of their technical proposal. The software utilized for the initial schedule shall not vary throughout the remainder of the design process.

The Contractor shall only utilize equivalent or compatible software for a project, which has received written approval from the Department. Forty State Business Days will be required for review and approval or rejection of the software. In order to obtain approval of a Substitutes or "Or Equal" product, the manufacturer of the software must demonstrate its compatibility by submitting all required documentation, demonstration disks, or other necessary information to the Bureau of Quality Management Services. The approved software utilized will not vary throughout the construction phase.

C. Best Practices

In developing a schedule, three basic items make CPM scheduling work:

- Clearly defined activities.
- Realistic duration's.
- Good logic.

Other Practices Include:

- Negative lags will not be permitted.
- Do not use a Finish to Start relationship with a lag. An activity must be added to represent the lag time.
- A project shall have one beginning and one end. All activities shall have a predecessor and successor except the project's start and finish milestones. No "Open Ends" will be permitted.
- Durations of work activities shall not exceed the update cycle. The Department requires the update cycle to be prepared monthly.
- "Suspension of Dates" will not be permitted. An activity must be added.
- If an activity has a Start-to-Start relationship - it shall be closed with a Finish-to-Finish or Finish-to-Start relationship. (No open ends)
- The completion date of the CPM schedule shall be the completion date in Subsection 108.10 of the project's Special Provisions, which shall be input as a Finish Milestone with a Late Finish Constraint. All intermediate milestones (Interim Completion Dates) required in the Contract shall be shown in proper logical sequence and input as either the "Start-no-Earlier-Than" or "Finish-no-Later-Than" date. Mandatory Finish and Mandatory Starts shall not be used.
- When updating, all "Out of Sequence" activities shall be corrected to reflect the current construction operations.
- Original durations shall not be changed from the approved Baseline Schedule.

D. Standard Coding

As a means of monitoring progress schedules, the Department has developed with the Consultant and Construction industries common coding structure and procedures to be utilized from design through construction. A Designer or Contractor shall utilize the Primavera template project containing the latest standard coding provided from the Department's web site or will be sent upon request.

D. I Development of Progress Schedules

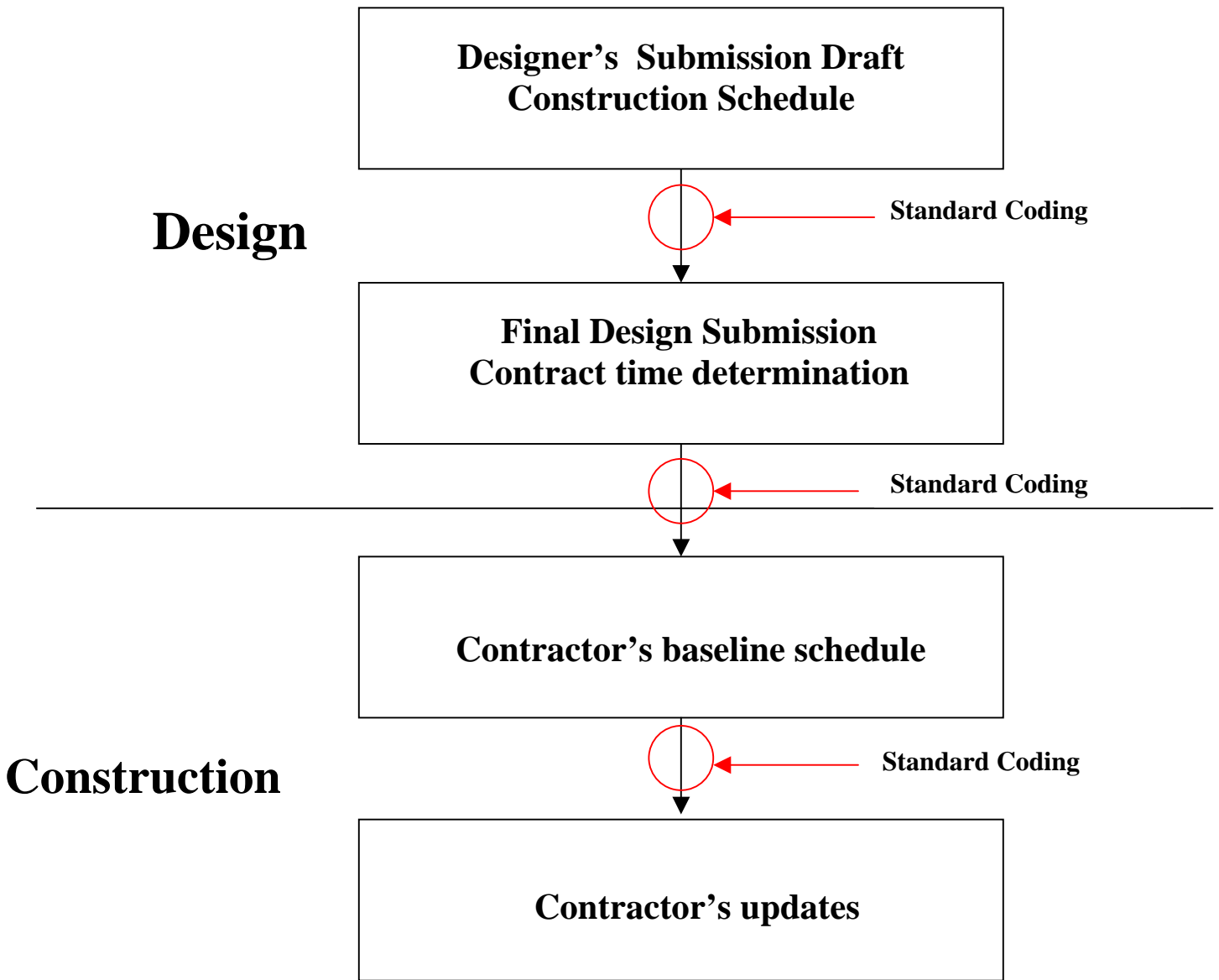

Key - Global link of all projects

D. II Design/Construction Template (WBS)

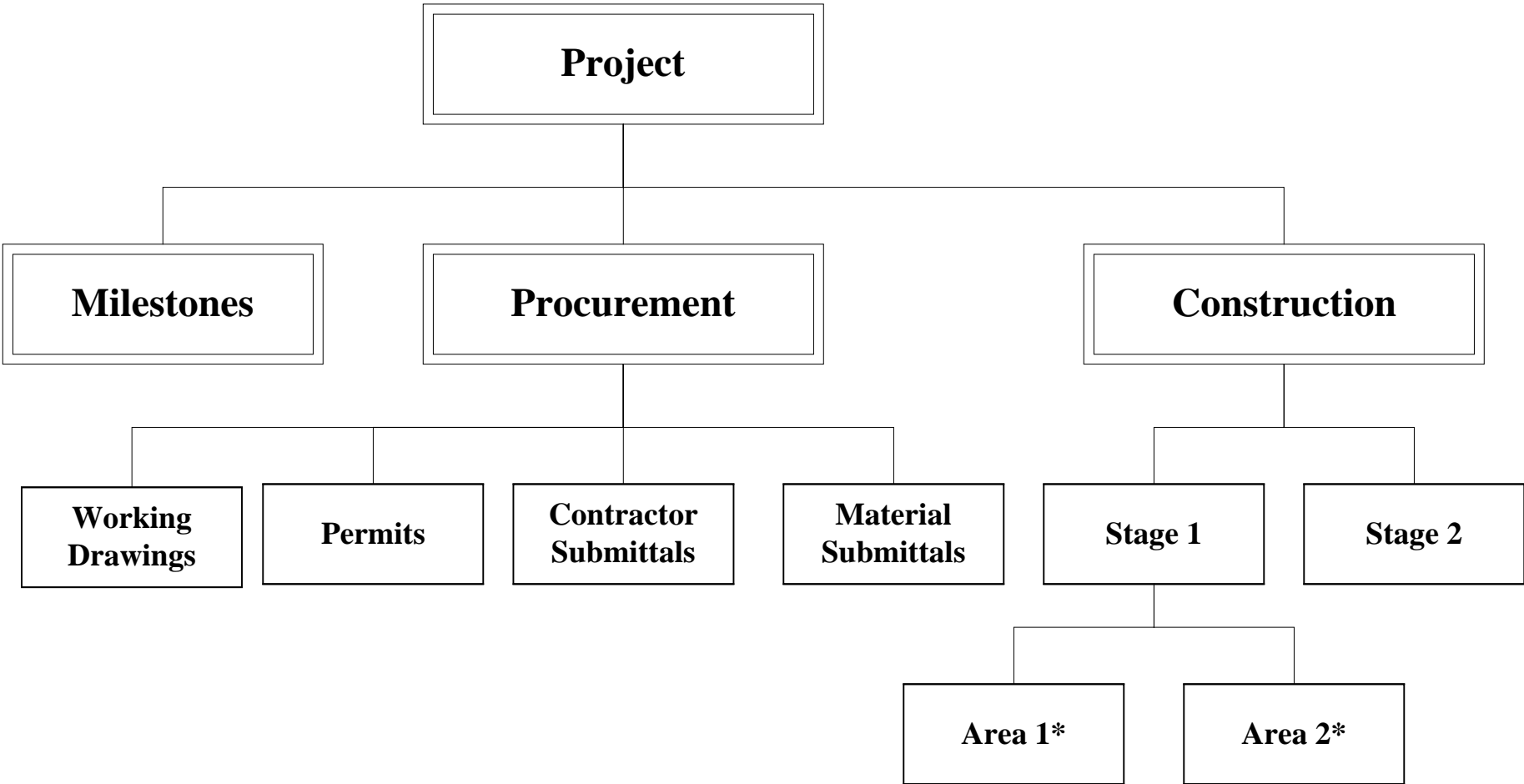

* User defined by Area Codes

D. III. Work Breakdown Structure (WBS)

Milestones

ACTIVITY ID	ACTIVITY DESCRIPTION
M100	Advertise Date (Start Milestone)
M200	Bid Date (Start Milestone)
M300	Award Date (Start Milestone)
M400	Start Design Work (Design/Build only) (Start Milestone)
M480	Complete Design Work (Design/Build only) (Finish Milestone)
M500	Construction Start Date (Start Milestone)
M600	Stage_ Complete (increase by 5) (Finish Milestone)
M700	Interim Completion Date(s) (Increase by 10) (Finish Milestone)
M800	ROW Availability Date(s) (Increase by 5) (Finish Milestone)
M900	Substantial Completion (Finish Milestone)
M950	Completion (Finish Milestone)

PRIMAVERA PROJECT PLANNER

WORK BREAKDOWN STRUCTURE

WBS Code Title

0 Milestones

C Construction

C.00 Administrative

C.01 Stage 1

C.01.1A Stage 1 A
C.01.1B Stage 1 B
C.01.1C Stage 1 C
C.01.1D Stage 1 D
C.01.1E Stage 1 E

C.02 Stage 2

C.02.2A Stage 2 A
C.02.2B Stage 2 B
C.02.2C Stage 2 C
C.02.2D Stage 2 D
C.02.2E Stage 2 E

- C.03 Stage 3**
 - C.03.3A Stage 3 A
 - C.03.3B Stage 3 B
 - C.03.3C Stage 3 C
 - C.03.3D Stage 3 D
 - C.03.3E Stage 3 E

- C.04 Stage 4**
 - C.04.4A Stage 4 A
 - C.04.4B Stage 4 B
 - C.04.4C Stage 4 C
 - C.04.4D Stage 4 D
 - C.04.4E Stage 4 E

- C.05 Stage 5**
 - C.05.5A Stage 5 A
 - C.05.5B Stage 5 B
 - C.05.5C Stage 5 C
 - C.05.5D Stage 5 D
 - C.05.5E Stage 5 E

- C.06 Stage 6**
 - C.06.6A Stage 6 A
 - C.06.6B Stage 6 B
 - C.06.6C Stage 6 C
 - C.06.6D Stage 6 D
 - C.06.6E Stage 6 E

- C. 7 Stage 7**
 - C.07.7A Stage 7 A
 - C.07.7B Stage 7 B
 - C.07.7C Stage 7 C
 - C.07.7D Stage 7 D
 - C.07.7E Stage 7 E

C.10 Final Cleanup

D Design (Design/Build only)

P Procurement

P.CS Contractor Submittals (Not Materials)

- P.CS.01 Safety Plan
- P.CS.02 Night Lighting
- P.CS.03 Demolition
- P.CS.04 Disposal
- P.CS.05 Paving
- P.CS.06 Steel Erection
- P.CS.07 Health and Safety Plan
- P.CS.08 Deck Placement

P.PP Permits

P.PP.01	Environmental
P.PP.02	Dewatering

P.MS Material Submittals (Long Lead Items)

P.MS .01	Concrete
P.MS .02	Structural Steel
P.MS .03	Asphalt
P.MS .04	Electrical
P.MS .05	Sheeting/Cofferdam

P.WD Working Drawings

P.WD .01	Bridge Working Drawings
P.WD.01.01	Bridge Working Drawings Requiring Design
P.WD.01.01.01	Structural Steel Working Drawings
P.WD.01.01.02	Structural Bearings
P.WD.01.01.03	Prestressed Concrete Beams
P.WD.01.01.04	Prestressed Concrete Piles
P.WD.01.01.05	Expansion Dams
P.WD.01.01.06	Cofferdams
P.WD.01.01.07	Sheeting
P.WD.01.01.08	Machinery for Movable Bridges
P.WD.01.01.09	Electrical Items for Movable Bridges
P.WD.01.01.10	Precast Concrete Culverts
P.WD.01.01.11	Steel Bridge Deck Forms
P.WD.01.01.12	Prefabricated Modular Walls
P.WD.01.01.13	Mechanical Stabilized Earth (MSE) Walls
P.WD.01.01.14	Concrete Crib Walls
P.WD.01.01.15	Alternate Retaining Wall Design
P.WD.01.01.16	Temporary Structures
P.WD.01.01.17	Temporary Shielding
P.WD.01.01.18	Electrical Items not pre-approved
P.WD.01.02	Bridge Working Drawings Not Requiring Design
P.WD.01.02.01	Structural Steel Working Drawings
P.WD.01.02.02	Structural Bearings
P.WD.01.02.03	Prestressed Concrete Beams
P.WD.01.02.04	Prestressed Concrete Piles
P.WD.01.02.05	Expansion Dams
P.WD.01.02.06	Cofferdams
P.WD.01.02.07	Machinery for Movable Bridges
P.WD.01.02.08	Electrical Items for Movable Bridges
P.WD.01.02.09	Strip Seals
P.WD.01.02.10	Armored Deck Joints
P.WD.01.02.11	Bridge Storm Drains
P.WD.01.02.12	Sign Support Structures
P.WD.01.02.13	GA Sign Support Posts
P.WD.01.02.14	Noise Barriers
P.WD.01.02.15	Bridge Railings and Fencing Anchorages
P.WD.01.02.16	Sign Legends

P.WD .02 Road Working Drawings

P.WD.02.01 Road requiring design

P.WD.02.01.01 Impact attenuators

P.WD.02.01.02 Sheeting

P.WD.02.01.03 Electrical items not pre-approved

P.WD.02.02 Road not requiring design

P.WD.02.02.01 Impact attenuators

P.WD.02.02.02 Sign legends

P.WD.02.02.03 Recycled/synthetic routed spacers

D. IV Standard Activity Codes

PRIMAVERA PROJECT PLANNER

ACTIVITY CODES DICTIONARY

CODE	VALUE	TITLE	SEQUENCE
------	-------	-------	----------

-Activity Codes:

RESP Responsibility

CONP		Prime Contractor	
CONA		Adjacent Contractor	
NACO		Army Corp of Engineers	
NCOG		Coast Guard	
NDBC		Delaware Bridge Commission	
NDEP		New Jersey DEP	
NDOT		New Jersey Department of Transportation	
NDPA		Delaware Port Authority	
NSJT		South Jersey Transportation Authority	
NGSP		NJ Highway Authority	
NPCM		Pinelands Commission	
NPPA		Palisades Parkway	
NPTA		Port Authority of NY and NJ	
NTPK		New Jersey Turnpike	
THRD		Third Party (Property owners, etc.)	
UACE		Atlantic City Electric DBA Connective	
UAMT		Amtrak	
UATT		AT&T	
UCBL		Cable Utility	
UCVE		City of Vineland Electric Co.	
UELG		Elizabethtown Gas	
UELW		Elizabethtown Water Company	
UGPN		JCP&L DBA GPU Energy - (North)	
UGPS		JCP&L DBA GPU Energy - (South)	
UMCI		MCI WorldCom	
UMIW		Middlesex Water	
UNGN		New Jersey Natural Gas (North)	
UNGS		New Jersey Natural Gas (South)	
UNJT		New Jersey Transit	
UNJW		New Jersey American Water	
UNWC		United Water Company	
UPEC		Public Service Electric (Central)	
UPEM		Public Service Electric (Metropolitan)	
UPEP		Public Service Electric (Palisades)	
UPES		Public Service Electric (Southern)	
UPGN		Public Service Gas (North)	
UPGS		Public Service Gas (South)	
UPVS		Passaic Valley Sewerage Commission	
UPVW		Passaic Valley Water Commission	
UREL		Rockland Electric	

URCR	Consolidated Rail Corporation
URNS	Norfolk and Southern Railroad
URCS	CSX Transportation Inc.
URNY	New York Susquehanna & Western Railway Corporation
USCC	Sprint Communications Company L.P.
USJG	South Jersey Gas
USPT	Sprint DBA United Telephone Co of NJ
UVER	Verizon Communications

0100	Atlantic County
0101	Absecon City
0102	Atlantic City
0103	Brigantine City
0104	Buena Borough
0105	Buena Vista Township
0106	Corbin City
0107	Egg Harbor City
0108	Egg Harbor Township
0109	Estell Manor City
0110	Folsom Borough
0111	Galloway Township
0112	Hamilton Township
0113	Hammonton Town
0114	Lindwood City
0115	Longport Borough
0116	Margate City
0117	Mullica Township
0118	Northfield City
0119	Pleasantville City
0120	Port Republic City
0121	Somers Point City
0122	Ventnor City
0123	Weymouth Township
0200	Bergen County
0201	Allendale Borough
0202	Alpine Borough
0203	Bergenfield Borough
0204	Bogota Borough
0205	Carlstadt Borough
0206	Cliffside Park Borough
0207	Closter Borough
0208	Cresskill Borough
0209	Demarest Borough
0210	Dumont Borough
0212	East Rutherford Borough
0213	Edgewater Borough
0211	Elmwood Park Borough
0214	Emerson Borough
0215	Englewood City
0216	Englewood Cliff Borough
0217	Fair Lawn Borough
0218	Fairview Borough
0219	Fort Lee Borough
0220	Franklin Lakes Borough
0221	Garfield City
0222	Glen Rock Borough
0223	Hackensack City
0224	Harrington Park Borough

0225	Hasbrouck Heights Borough
0226	Haworth Borough
0227	Hillsdale Borough
0228	Hohokus Borough
0229	Leonia Borough
0230	Little Ferry Borough
0231	Lodi Borough
0232	Lyndhurst Township
0233	Mahwah Township
0234	Maywood Borough
0235	Midland Park Borough
0236	Montvale Borough
0237	Moonachie Borough
0238	New Milford Borough
0239	North Arlington Borough
0240	Northvale Borough
0241	Norwood Borough
0242	Oakland Borough
0243	Old Tappan Borough
0244	Oradell Borough
0245	Palisades Park Borough
0246	Paramus Borough
0247	Park Ridge Borough
0248	Ramsey Borough
0249	Ridgefield Borough
0250	Ridgefield Park Village
0251	Ridgewood Village
0252	River Edge Borough
0253	Rivervale Township
0254	Rochelle Park Township
0255	Rockleigh Borough
0256	Rutherford Borough
0257	Saddle Brook Township
0258	Saddle River Borough
0259	South Hackensack Township
0260	Teaneck Township
0261	Tenafly Borough
0262	Teterboro Borough
0263	Upper Saddle River Borough
0264	Waldwick Borough
0265	Wallington Borough
0266	Washington Township
0267	Westwood Borough
0268	Woodcliff Lake Borough
0269	Wood Ridge Borough
0270	Wyckoff Township
0300	Burlington County
0301	Bass River Township
0302	Beverly City
0303	Bordentown City
0304	Bordentown Township

0305	Burlington City
0306	Burlington Township
0307	Chesterfield Township
0308	Cinnaminson Township
0309	Delanco Township
0310	Delran Township
0311	Eastampton Township
0312	Edgewater Park Township
0313	Evesham Township
0314	Fieldsboro Borough
0315	Florence Township
0316	Hainesport Township
0317	Lumberton Township
0318	Mansfield Township
0319	Maple Shade Township
0320	Medford Township
0321	Medford Lakes Borough
0322	Moorestown Township
0323	Mount Holly Township
0324	Mount Laurel Township
0325	New Hanover Township
0326	North Hanover Township
0327	Palmyra Borough
0328	Pemberton Borough
0329	Pemberton Township
0330	Riverside Township
0331	Riverton Borough
0332	Shamong Township
0333	Southampton Township
0334	Springfield Township
0335	Tabernacle Township
0336	Washington Township
0337	Westampton Township
0338	Willingboro Township
0339	Woodland Township
0340	Wrightstown Borough
0400	Camden County
0401	Audubon Borough
0402	Audubon Park Borough
0403	Barrington Borough
0404	Bellmawr Borough
0405	Berlin Borough
0406	Berlin Township
0407	Brooklawn Borough
0408	Camden City
0409	Cherry Hill Township
0410	Chesilhurst Borough
0411	Clementon Borough
0412	Collingswood Borough
0413	Gibbsboro Borough
0414	Gloucester City

0415	Gloucester Township
0416	Haddon Township
0417	Haddonfield Borough
0418	Haddon Heights Borough
0419	Hi Nella Borough
0420	Laurel Springs Borough
0421	Lawnside Borough
0422	Lindenwold Borough
0423	Magnolia Borough
0424	Merchantville Borough
0425	Mount Ephraim Borough
0426	Oaklyn Borough
0427	Pennsauken Township
0428	Pine Hill Borough
0429	Pine Valley Borough
0430	Runnemede Borough
0431	Somerdale Borough
0432	Stratford Borough
0433	Tavistock Borough
0434	Voorhees Township
0435	Waterford Township
0436	Winslow Township
0437	Woodlynne Borough
0500	Cape May County
0501	Avalon Borough
0502	Cape May City
0503	Cape May Point Borough
0504	Dennis Township
0505	Lower Township
0506	Middle Township
0507	North Wildwood City
0508	Ocean City
0509	Sea Isle City
0510	Stone Harbor Borough
0511	Upper Township
0512	West Cape May Borough
0513	West Wildwood Borough
0514	Wildwood City
0515	Wildwood Crest Borough
0516	Woodbine Borough
0600	Cumberland County
0601	Bridgeton City
0602	Commercial Township
0603	Deerfield Township
0604	Downe Township
0605	Fairfield Township
0606	Greenwich Township
0607	Hopewell Township
0608	Lawrence Township
0609	Maurice River Township
0610	Millville City

	0611	Shiloh Borough
	0612	Stow Creek Township
	0613	Upper Deerfield Township
	0614	Vineland City
0700		Essex County
	0701	Belleville Township
	0702	Bloomfield Township
	0703	Caldwell Borough Township
	0704	Cedar Grove Township
	0705	Ease Orange City
	0706	Essex Fells Township
	0707	Fairfield Township
	0708	Glen Ridge Township
	0709	Irvington Township
	0710	Livingston Township
	0711	Maplewood Township
	0712	Millburn Township
	0713	Montclair Township
	0714	Newark City
	0715	North Caldwell Township
	0716	Nutley Township
	0717	Orange City Township
	0718	Roseland Borough
	0719	South Orange Village Township
	0720	Verona Township
	0721	West Caldwell Township
	0722	West Orange Township
0800		Gloucester County
	0801	Clayton Borough
	0802	Deptford Township
	0803	East Greenwich Township
	0804	Elk Township
	0805	Franklin Township
	0806	Glassboro Borough
	0807	Greenwich Township
	0808	Harrison Township
	0809	Logan Township
	0810	Mantua Township
	0811	Monroe Township
	0812	National Park Borough
	0813	Newfield Borough
	0814	Paulsboro Borough
	0815	Pitman Borough
	0816	South Harrison Township
	0817	Swedesboro Borough
	0818	Washington Township
	0819	Wenonah Borough
	0820	West Deptford Township
	0821	Westville Borough
	0822	Woodbury City
	0823	Woodbury Heights Borough

	0824	Woolwich Township
0900		Hudson County
	0901	Bayonne City
	0902	East Newark Borough
	0903	Guttenberg Town
	0904	Harrison Town
	0905	Hoboken City
	0906	Jersey City
	0907	Kearny Town
	0908	North Bergen Township
	0909	Secaucus Town
	0910	Union City
	0911	Weehawken Township
	0912	West New York Town
1000		Hunderton County
	1001	Alexandria Township
	1002	Bethlehem Township
	1003	Bloomsbury Borough
	1004	Califon Borough
	1005	Clinton Town
	1006	Clinton Township
	1007	Delaware Township
	1008	East Amwell Township
	1009	Flemington Borough
	1010	Franklin Township
	1011	Frenchtown Borough
	1012	Glen Gardner Borough
	1013	Hampton Borough
	1014	High Bridge Borough
	1015	Holland Township
	1016	Kingwood Township
	1017	Lambertville City
	1018	Lebanon Borough
	1019	Lebanon Township
	1020	Milford Borough
	1021	Raritan Township
	1022	Readington Township
	1023	Stockton Borough
	1024	Tewksbury Township
	1025	Union Township
	1026	West Amwell Township
1100		Mercer County
	1101	East Windsor Township
	1102	Ewing Township
	1103	Hamilton Township
	1104	Hightstown Borough
	1105	Hopewell Borough
	1106	Hopewell Township
	1107	Lawrence Township
	1108	Pennington Borough
	1109	Princeton Borough

	1110	Princeton Township
	1111	Trenton City
	1112	Washington Township
	1113	West Windsor Township
1200		Middlesex County
	1201	Carteret Borough
	1202	Cranbury Township
	1203	Dunellen Borough
	1204	East Brunswick Township
	1205	Edison Township
	1206	Helmetta Borough
	1207	Highland Park Borough
	1208	Jamesburg Borough
	1209	Metuchen Borough
	1210	Middlesex Borough
	1211	Milltown Borough
	1212	Monroe Township
	1213	New Brunswick City
	1214	North Brunswick Township
	1215	Old Bridge Township
	1216	Perth Amboy City
	1217	Piscataway Township
	1218	Plainsboro Township
	1219	Sayreville Borough
	1220	South Amboy City
	1221	South Brunswick Township
	1222	South Plainfield Borough
	1223	South River Borough
	1224	Spotswood Borough
	1225	Woodbridge Township
1300		Monmouth County
	1301	Aberdeen Township
	1302	Allenhurst Borough
	1303	Allentown Borough
	1304	Asbury Park City
	1305	Atlantic Highlands Borough
	1306	Avon By The Sea Borough
	1307	Belmar Borough
	1308	Bradley Beach Borough
	1309	Brielle Borough
	1310	Colts Neck Township
	1311	Deal Borough
	1312	Eatontown Borough
	1313	Englishtown Borough
	1314	Fair Haven Borough
	1315	Farmingdale Borough
	1316	Freehold Borough
	1317	Freehold Township
	1318	Hazlet Township
	1319	Highlands Borough
	1320	Holmdel Township

1321	Howell Township
1322	Interlaken Borough
1323	Keansburg Borough
1324	Keyport Borough
1325	Little Silver Borough
1326	Loch Arbour Village
1327	Long Branch City
1328	Manalapan Township
1329	Manasquan Borough
1330	Marlboro Township
1331	Matawan Borough
1332	Middletown Township
1333	Millstone Township
1334	Monmouth Beach Borough
1335	Neptune Township
1336	Neptune City Borough
1337	Ocean Township
1338	Oceanport Borough
1339	Red Bank Borough
1340	Roosevelt Borough
1341	Rumson Borough
1342	Sea Bright Borough
1343	Sea Girt Borough
1344	Shrewsbury Borough
1345	Shrewsbury Township
1346	South Belmar Borough
1347	Spring Lake Borough
1348	Spring Lake Heights Borough
1349	Tinton Falls Borough
1350	Union Beach Borough
1351	Upper Freehold Township
1352	Wall Township
1353	West Long Branch Boro
1400	Morris County
1401	Boonton Town
1402	Boonton Township
1403	Butler Borough
1404	Chatham Borough
1405	Chatham Township
1406	Chester Borough
1407	Chester Township
1408	Denville Township
1409	Dover Town
1410	East Hanover Township
1411	Florham Park Borough
1412	Hanover Township
1413	Harding Township
1414	Jefferson Township
1415	Kinnelon Borough
1416	Lincoln Park Borough
1417	Madison Borough

1418	Mendham Bourough
1419	Mendham Township
1420	Mine Hill Township
1421	Montville Township
1422	Morris Township
1423	Morris Plains Borough
1424	Morristown Town
1425	Mountain Lakes Borough
1426	Mt. Arlington Borough
1427	Mt. Olive Township
1428	Netcong Borough
1429	Parsippany-Troy Hills Township
1430	Long Hill Township
1431	Pequannock Township
1432	Randolph Township
1433	Riverdale Borough
1434	Rockaway Borough
1435	Rockaway Township
1436	Roxbury Township
1437	Victory Gardens Borough
1438	Washington Township
1439	Wharton Borough
1500	Ocean County
1501	Barnegat Township
1502	Barnegat Light Borough
1503	Bay Head Borough
1504	Beach Haven Borough
1505	Beachwood Borough
1506	Berkeley Township
1507	Brick Township
1508	Dover Township
1509	Eagleswood Township
1510	Harvey Cedars Borough
1511	Island Heights Borough
1512	Jackson Township
1513	Lacey Township
1514	Lakehurst Borough
1515	Lakewood Township
1516	Lavalette Borough
1517	Little Egg Harbor Township
1518	Long Beach Township
1519	Manchester Township
1520	Mantoloking Borough
1521	Ocean Township
1522	Ocean Gate Borough
1523	Pine Beach Borough
1524	Plumsted Township
1525	Point Pleasant Borough
1526	Point Pleasant Beach Borough
1527	Seaside Heights Borough
1528	Seaside Park Borough

	1529	Ship Bottom Borough
	1530	South Toms River Borough
	1531	Stafford Township
	1532	Surf City Borough
	1533	Tuckerton Borough
1600		Passaic County
	1601	Bloomington Borough
	1602	Clifton City
	1603	Haledon Borough
	1604	Hawthorne Borough
	1605	Little Falls Township
	1606	North Haledon Borough
	1607	Passaic City
	1608	Paterson City
	1609	Pompton Lakes Borough
	1610	Prospect Park Borough
	1611	Ringwood Borough
	1612	Totowa Borough
	1613	Wanaque Borough
	1614	Wayne Township
	1615	West Milford Township
	1616	West Paterson Borough
1700		Salem County
	1701	Alloway Township
	1702	Carneys Point Township
	1703	Elmer Borough
	1704	Elsinboro Township
	1705	Lower Alloways Crk. Township
	1706	Mannington Township
	1707	Oldsman Township
	1708	Penns Grove Borough
	1709	Pennsville Township
	1710	Pilesgrove Township
	1711	Pittsgrove Township
	1712	Quinton Township
	1713	Salem Township
	1714	Upper Pittsgrove Township
	1715	Woodstown Borough
1800		Somerset County
	1801	Bedminster Township
	1802	Benards Township
	1803	Benardsville Borough
	1804	Bound Brook Borough
	1805	Branchburg Township
	1806	Bridgewater Township
	1807	Far Hills Borough
	1808	Franklin Township
	1809	Green Brook Twonship
	1810	Hillsborough Township
	1811	Manville Borough
	1812	Millstone Borough

1813	Montgomery Township
1814	North Plainfield Borough
1815	Peapack-Gladstone Borough
1816	Raritan Borough
1817	Rocky Hill Borough
1818	Somerville Borough
1819	South Bound Brook Borough
1820	Warren Township
1821	Watchung Borough
1900	Sussex County
1901	Andover Borough
1902	Andover Township
1903	Branchville Borough
1904	Byram Township
1905	Frankford Township
1906	Franklin Borough
1907	Fredon Township
1908	Green Township
1909	Hamburg Borough
1910	Hampton Township
1911	Hardyston Township
1912	Hopatcong Borough
1913	Lafayette Township
1914	Montague Township
1915	Newton Town
1916	Ogdensburg Borough
1917	Sandyston Township
1918	Sparta Township
1919	Stanhope Borough
1920	Stillwater Township
1921	Sussex Borough
1922	Vernon Township
1923	Walpack Township
1924	Wantage Township
2000	Union County
2001	Berkeley Heights Township
2002	Clark Township
2003	Cranford Township
2004	Elizabeth City
2005	Fanwood Borough
2006	Garwood Borough
2007	Hillside Township
2008	Kenilworth Borough
2009	Linden City
2010	Mountainside Borough
2011	New Providence Borough
2012	Plainfield City
2013	Rahway City
2014	Roselle Borough
2015	Roselle Park Borough
2016	Scotch Plains Township

	2017	Spingfield Township
	2018	Summit City
	2019	Union Township
	2020	Westfield Town
	2021	Winfield Township
2100		Warren County
	2101	Allamuchy Township
	2102	Alpha Borough
	2103	Belvidere Town
	2104	Blairstown Township
	2105	Franklin Township
	2106	Frelinghuysen Township
	2107	Greenwich Township
	2108	Hackettstown Town
	2109	HardwickTownship
	2110	Harmony Township
	2111	Hope Township
	2112	Independence Township
	2113	Knowlton Township
	2114	Liberty Township
	2115	Lopatcong Township
	2116	Mansfield Township
	2117	Oxford Township
	2119	Phillipsburg Town
	2120	Pohatcong Township
	2121	Washington Borough
	2122	Washington Township
	2123	White Township

CLAS Class of Work

BRID Bridge items

Type of Work

SHEE	Sheeting
BDST	Clearing site, bridge
COCU	Concrete culverts
PILE	Piles
WALL	Noise Barrier
BRST	Temporary Shielding
COFF	Cofferdams
REIN	Reinforcing Steel
TEST	Temporary Structure
DECK	Deck Repair
CONS	Structural Concrete
DIVE	Underwater Inspection
STEL	Structural Steel
PREC	Precast/Prestressed Beams
OSIG	Overhead/Cantilever signs
BEXC	Bridge Excavation
BMIC	Bridge Miscellaneous (Fence, railing, joints, guiderail etc.)

CLAS Class of Work

ROAD Road Items

Type of Work

CLER	Clearing site items
DRAN	Drainage items
EART	Earthwork items
PAVE	Asphalt Pavement items
LAND	Landscape items
UTIL	Utility items
MISC	Miscellaneous items
ELEC	Electrical and Signal items
CURB	Curb items
MAIN	Maintenance of traffic items
LTSD	Traffic stripes, signs and delineators
AGGR	Aggregates (Subbase, DGABC, etc.)
ITSW	ITS Work
CONC	Concrete Pavement
DEMO	Demolition
ENVR	Environmental
MILL	Milling
SLAB	Approach and Transition Slabs
RCSC	Removal of Concrete Base and Roadway
RDST	Removal of curb
WALK	Sidewalks and Driveways
THLS	Temporary Lighting
FENC	Fence
BRAL	Beam Guide Rail

AREP Project Area (Values of YYYY will be the name of the project – Last two places – user defined)

YYYYA1	Area 1 (Description to be defined by user)
YYYYA2	Area 2 (Description to be defined by user)
YYYYA3	Area 3 (Description to be defined by user)
YYYYA4	Area 4 (Description to be defined by user)
YYYYA5	Area 5 (Description to be defined by user)
YYYYA6	Area 6 (Description to be defined by user)
YYYYA7	Area 7 (Description to be defined by user)
YYYYA8	Area 8 (Description to be defined by user)
YYYYA9	Area 9 (Description to be defined by user)
YYYYB1	Area 10 (Description to be defined by user)

E. Standard Factors

Standard factors that shall be taken into account when preparing a Construction Schedule include:

1. Scheduling the advertisement of small, short duration projects in order to allow construction to be completed in one construction season (Designer Contract Time Determination only).
2. Seasonal limitations such as concrete construction, paving, Hot Mix Asphalt (HMA) availability, curb, placement of long life traffic stripes, landscaping and bridge painting.
3. Utility relocation's (each utility treated separately - work on the same pole line must be treated sequentially, not concurrently).
4. No natural gas service interruptions during the winter months. Normally from October 1 to April 1, to be verified through the Utility and Railroad Engineering Unit.
5. No water service interruptions during the summer months. Normally from April 1 to September 30 to be verified through the Utility and Railroad Engineering Unit.
6. Right-of-way availability (each parcel treated separately).
7. Work hour restrictions due to staging and traffic volumes.
8. Marine, bridge openings, or railroad traffic.
9. Staged construction.
10. Concrete curing time.
11. Embankment settlement time.
12. Coordination with other projects.
13. Winter shutdown.
14. Working drawing processing and approvals (each one treated separately).
15. Availability, fabrication and delivery of materials. This shall include an analysis of any "Buy American" requirements.
16. Permit restrictions (fish spawning, etc.).
17. Work area restrictions (wetlands, historic sites, parkland, etc.).
18. Hazardous material excavation and disposal.
19. Payment restrictions due to limits in multi-year funding.

20. Work restrictions due to local activities, holiday seasons on roads with shopping centers, or in seasonal areas such as shore communities.
21. Impacts to Authorities. (i.e. NJ Turnpike, NJ Highway Authority, South Jersey Transportation Authority etc.)

F. Level of Detail Required on a Progress Schedule

The network shall include, as a minimum, one activity for each discrete component part of each Pay Item scheduled in the Proposal. The Engineer may allow grouping of similar Pay Items.

G. Designer Contract Time Determination

Establishing proper completion dates for a construction project is more important today than ever before. Most construction projects involve the reconstruction of existing highways which traffic must be maintained with lane and shoulder restrictions during reconstruction. A Construction progress schedule shall establish a completion date that provides the shortest practical duration of construction to minimize disruption of traffic but still allows the contractor a reasonable amount of time to complete the work at a reasonable cost. Tables G.IV.a through G.IV.h, Contractor Production Rates, shall be used **as a guide** to determine the construction schedule.

A detailed breakdown of the bridge items and road items is needed on the Construction progress schedules. This is necessary to determine if increased production rates or additional crews are required to meet a desired completion date. Where ranges of production rates are shown, the lower rates are for two-lane bridges and the higher rates are for bridges with more than two lanes. The Designer shall also take into account the complexity of the work, fabrication time, the site conditions, traffic effects and all other factors when choosing a production rate.

In the appendix there is a chart showing the statewide average number of working days for roadway (R) and bridge (B). The average total working days per calendar year is 165 for roadway and 185 for bridge. The number of days per month for roadway and bridgework shall be adjusted downward in the northern part of the State, and adjusted upward in the southern part of the State. If weekend work is required, the total number of workdays per month must be adjusted. If a different number of working days is used, the Designer shall provide a written explanation with the Construction Progress Schedule. The Designer shall also look at the types and classes of work performed during the winter season. Adjustments shall be made based on whether work can be performed during this time frame. An anticipated total number of workdays for Bridgework and Roadwork shall be provided between December through March inclusive.

The full width of the traveled way and shoulders should be open to traffic whenever conditions permit during a winter shutdown. Consideration shall be given to setting interim completion dates for stages of construction and for portions of the work that significantly affect traffic.

G.I. Design Submission

Construction progress schedules are prepared and submitted by the Designer with the design submission utilizing approved scheduling software, standard format, coding and structure. Quality Assurance, Constructibility and Schedule Reviews will be performed at this time. The method of project delivery will also be recommended at this point. In addition to the number of hard copies distributed, the Designer shall submit four (4) copies of the schedule in electronic format on a 3-1/2" floppy diskette or compact disk for review.

Distribution of the construction progress schedules shall be as follows:

Group	Hard Copy	Electronic
Project Manager	X	X
Regional Field Manager	X	X
Bureau of Construction Engineering	X	X
Construction Scheduling Unit	X	X
Estimating Unit	X	
Contract Document Review Unit	X	
Traffic Operations	X	
QA Team Leader	X	
FHWA (Full oversight projects)	X	
Geotechnical Engineering – Structures	Copies are available upon request from the Construction Scheduling Unit	
Geometric Design – Pavements		
Landscape		
Structural Design		
Utilities		
Right of Way		

Increased production rates may require the use of multiple crews and/or overtime. This additional cost shall be reflected in the Construction Cost Estimate. Also, the use of a bonus for early completion may be appropriate (Refer to G.VII). The Estimating Unit, and Construction Scheduling Unit shall be consulted to determine when such provisions are to be used.

G.II. Final Submission

Construction progress schedules are prepared and submitted by the Designer with the final design submission utilizing approved scheduling software, standard format, coding and structure. Quality Assurance, Constructibility and Schedule Reviews will be performed at this time. In addition to the number of hard copies required, the Designer shall submit four (4) copies of the schedule in electronic format on a 3-1/2” floppy diskette or compact disk.

Distribution of the construction progress schedules shall be as follows:

Group	Hard Copy	Electronic
Project Manager	X	X
Regional Field Manager	X	X
Bureau of Construction Engineering	X	X
Construction Scheduling Unit	X	X
Estimating Unit	X	
Contract Document Review Unit	X	
Traffic Operations	X	
QA Team Leader	X	
FHWA (Full oversight projects)	X	
Geotechnical Engineering – Structures	Copies are available upon request from the Construction Scheduling Unit	
Geometric Design – Pavements		
Landscape		
Structural Design		
Utilities		
Right of Way		

Quality Management Service will review and input the following:

- set completion date and milestones
- method of project delivery and requirements (i.e. I/D, acceleration etc.)
- liquidated damages

G. III Designer Standard Naming of Projects

The Designer shall assign a four-character file name. The first two characters will be the project identifier. The last two digits will be as follows:

- I0 - Design submission
- I1 - Design submission revised
- Etc.
- F1 - Final submission
- F2 - Final submission revised
- Etc.

The type of each submission shall be clearly labeled in the description field.

G. IV. Multi - Year Funding

If during development of the Capital Program it is determined that a project may need to be multi-year funded, the Project Manager shall provide to the Capital Program Development a breakdown of the estimated construction cost per fiscal year based on the construction staging of the project. The Designer is responsible for developing a cost loaded CPM including the cost breakdown by activity and year.

G. V. Determining Start of Construction:

From Final Design Submission to Plans, Specifications and Estimate (PS&E) Submission - is approximately 12 weeks. Add 4 weeks for FHWA full oversight funded projects to allow for Preliminary PS&E review. Additional time may be considered for review and revisions on larger projects and / or projects with outstanding issues at the Final Design Submissions (FDS) (permits, ROW, utilities, etc.).

From PS&E Submission to Advertisement - 3 weeks for 100 percent State funded projects, 4 weeks for FHWA alternate procedure(NHS or non-NHS projects, and 5 weeks for other federally funded projects.

From Advertising to Receipt of Bids – A minimum of 3 weeks is required for bidding, with additional time allowed for larger or complex projects. *

From Receipt of Bids to Award – 15 State Business Days. **

From Award to Construction - Award to Execution of the Contract will vary up to 55 State Business Days. The construction start date of the CPM Schedule shall be the Contract Start Date (25 calendar days after the execution of the Contract.) **

* In general, shorter time frames are appropriate for 100 percent State funded projects. Longer time frames shall be used on Federally Projects requiring full oversight, or those projects requiring third party or local funding participation prior to contract execution. The Bureau of Contract Administration Services should be consulted by the Project Manager to verify that the time frames used by the Designer are appropriate.

** The Bureau of Construction Services should be consulted by the Project Manager to verify that the time frames used by the Designer are appropriate.

**G. VI.a TABLE A (ENGLISH)
CONTRACTOR'S PRODUCTION RATES FOR ROADWAY ITEMS**

ITEM	Type 1 Construction	Type 2 Reconstruction	Type 3 Widening	Type 4 Resurfacing	Type 5 Intersections
Mobilization	10 Days*	10 Days*	5 Days	2 Days	2 Days
Clearing Site Including Stripping	4 Acres	4 Acres	4 Acres	N/A	N/A
Removal of Vertical Curb	N/A	1000 LF	700 LF	400 LF	400 LF
Demolition of Buildings	1 Unit	1 Unit	1 Unit	N/A	N/A
Pest Control	10 Days	10 Days	10 Days	N/A	N/A
Asbestos Clean-up Resident and Small Commercial	4 Days	4 Days	4 Days	N/A	N/A
Large Commercial	10 Days	10 Days	10 Days		
Removal of Bituminous Concrete Overlay	N/A	2500 SY	2500 SY	2500 SY	300 SY
Roadway Excavation Embankment	3000 CY	1000 CY	1000 CY	N/A	N/A
Wet Excavation	1500 CY	350 CY	350 CY	N/A	N/A
Drainage Pipe Includes 1 Structure					
36 inches and Smaller	300 LF	150 LF	150 LF	N/A	150 LF
Larger than 36 inches	100 LF	60 LF	60 LF	N/A	60 LF
Reset Castings	N/A	5 Units	5 Units	5 Units	5 Units
Extension Frames and Rings	N/A	12 Units	12 Units	12 Units	12 Units
Subbase	350 CY	250 CY	150 CY	N/A	50 CY
Aggregate Base Course	350 CY	250 CY	150 CY	N/A	50 CY
Bituminous Concrete Base or Surface Course	1500 TONS	1000 TONS	750 TONS	1300 TONS	250 TONS
Portland Cement Concrete Base or Surface Course	2500 SY	1000 SY	750 SY	N/A	225 SY

Note: Production Rates are based on 8-hour working day per crew.

TYPE 1 = New construction, additions or major reconstruction of divided or undivided highways.

TYPE 2 = Reconstruction or upgrading existing highways.

TYPE 3 = Widening (less than one lane) and resurfacing existing highways.

TYPE 4 = Resurfacing existing highways with bituminous concrete.

TYPE 5 = Minor construction or reconstruction of street or highway intersections.

* = Use 20 days when \$20 million or higher.

TABLE A (Con't) (ENGLISH)
CONTRACTOR'S PRODUCTION RATES FOR ROADWAY ITEMS

ITEM	Type 1 Construction	Type 2 Reconstruction	Type 3 Widening	Type 4 Resurfacing	Type 5 Intersections
Bridge Approach Slabs or Transition Slabs	200 SY	200 SY	200 SY	N/A	N/A
Milling (up to 2 inches thick)	N/A	6000 SY	6000 SY	6000 SY	2500 SY
Concrete Barrier Curb	400 LF	350 LF	350 LF	250 LF	N/A
Concrete Vertical Curb	500 LF	400 LF	400 LF	300 LF	200 LF
Concrete Sidewalk	225 SY	200 SY	200 SY	150 SY	150 SY
Electrical Conduit	600 LF	400 LF	400 LF	150 LF	150 LF
Fiber Optic Conduit	1000 LF	1000 LF	1000 LF	1000 LF	N/A
Electrical Wire	1200 LF	1200 LF	1200 LF	300 LF	300 LF
Lighting Standards	4 Unit	4 Unit	4 Unit	N/A	4 Unit
Traffic Signal Installation (1)	20 Days per Intersection	20 Days per Intersection	20 Days per Intersection	20 Days per Intersection	20 Days per Intersection
Reset Beam Guide Rail	N/A	500 LF	500 LF	400 LF	N/A
Beam Guide Rail	750 LF	750 LF	750 LF	500 LF	N/A
Chain Link Fence	400 LF	400 LF	400 LF	N/A	N/A
Overhead Sign Structure (2)	15 Days per Structure	15 Days per Structure	15 Days per Structure	15 Days per Structure	N/A
Landscaping, Turf	10,000 SY	10,000 SY	10,000 SY	N/A	N/A
Landscape, Planting (3)	Planting Season	Planting Season	Planting Season	Planting Season	N/A
Final Acceptance (4)	60 Calendar Days	60 Calendar Days	60 Calendar Days	30 Calendar Days	45 Calendar Days

Note: Production Rates are based on 8-hour working day per crew. (1) Manufacturing and delivery of steel traffic signal poles requires 4 months, aluminum lighting and traffic signal poles require 2 months and traffic signal controllers require 4 months.

- (2) Allow 2 months for working drawing approval, fabrication and delivery.
- (3) Planting seasons - from March 1 to May 1 and from August 15 to December 1.
- (4) Final Acceptance shall be 15 calendar days for resurfacing projects \$2 million or less.

**G. VI.b TABLE B (ENGLISH)
CONTRACTOR'S PRODUCTION RATES FOR BRIDGE ITEMS**

ITEM	Type 1 Construction	Type 2 Reconstruction	Type 3 Superstructure	Type 4 Deck	Type 5 Overlay
Cofferdams	20 days	20 days	N/A	N/A	N/A
Retaining Walls (1,3) (Cast-in-Place)	20 days / 100 LF	20 days/ 100 LF	N/A	N/A	N/A
Box Culverts (Cast-in-Place)	10 days/ 30 LF	10 days/ 30 LF	N/A	N/A	N/A
Box Culverts (2) (Precast)	5 days/ 30 LF	5 days/ 30 LF	N/A	N/A	N/A

Notes:

- Production Rates are based on 8-hour working day per crew.
- For two bridges add 50%, for each additional bridge add 25%.
- For Stage Construction, consider each stage to be a separate bridge.
- For bridges over water or railroads add 30 days, except for Type 5 for which no adjustment is necessary.
- Production rates include the time required for concrete curing.

- (1) Add 5 days per 100 LF if temporary sheeting is required.
- (2) Includes excavation and placing, allow 3-4 months for working drawing approval, fabrication and delivery.
- (3) Use for Reinforced Earth, Double Wall and Anchored Walls.

Type 1 = New Construction on new alignment.

Type 2 = Remove existing bridge and construct new bridge at same location.

Type 3 = Replace deck and beams including minor substructure repair.

Type 4 = Replace deck.

Type 5 = Deck patching and LMC overlay (subtract 10 days if overlay is bituminous concrete).

G. VI.c TABLE C (ENGLISH)
Bridge Item
Contractor Production Rates
One Span Bridge (40 to 100 feet Range)

BRIDGE TYPE/BRIDGE ITEM	TYPE 1	2	3	4	5
	NEW ON NEW ALIGNMENT	NEW ON SAME ALIGNMENT	SUPERSTRUCTURE REPLACEMENT	DECK REPLACEMENT	B, C & LMC
Demolition	--	16-28 days	8-16 days	7-14 days	--
Foundation Excavation	2-4 days	2-4 days	--	--	--
Piles	4-6 days	4-6 days	--	--	--
Footing	2-4 days	2-4 days	--	--	--
Abutment, Pier, & WW's	6-8 days	6-8 days	--	--	--
Substructure Curing	14 days	14 days	--	--	--
Framing	2-4 days	2-4 days	2-4 days	--	--
Deck Joints	2-4 days	2-4 days	2-4 days	2-4 days	2-4 days
Deck Forms	7-12 days	7-12 days	7-12 days	7-12 days	--
Shear Connectors	1-2 days	1-2 days	1-2 days	1-2 days	--
Deck	2-4 days	2-4 days	2-4 days	2-4 days	--
Deck Slab Curing	14 days	14 days	14 days	14 days	--
Header	1-2 days	1-2 days	1-2 days	1-2 days	--
Parapets	2 days	2 days	2 days	2 days	--
Preformed Joint	1 day	1 day	1 day	1 day	1 day
Railing/Fence	3 days	3 days	3 days	3 days	--
Sawcut Deck	1 day	1 day	1 day	1 day	1 day
Substructure Rehabilitation	--	--	6-12 days	2-4 days	--
Deck Repairs	--	--	--	--	6-12 days
LMC	--	--	--	--	2-4 days
LMC Curing	--	--	--	--	14 days
TOTAL	64-85 days	80-113 days	50-77 days	43-63 days	26-36 days

Allow 2 months (steel beams) and 3 months (concrete beams) for working drawing approval, fabrication and delivery. Designer shall verify anticipated timeframes prior to Final Submission.

G. VI.d TABLE D (ENGLISH)
Bridge Item
Contractor Production Rates
Two Span Bridge (180 to 200 feet Range)

BRIDGE TYPE/BRIDGE ITEM	TYPE 1	2	3	4	5
	NEW ON NEW ALIGNMENT	NEW ON SAME ALIGNMENT	SUPERSTRUCTURE REPLACEMENT	DECK REPLACEMENT	B, C & LMC
Demolition	--	26-48 days	16-32 days	14-28 days	--
Foundation Excavation	3-5 days	3-5 days	--	--	--
Piles	6-10 days	6-10 days	--	--	--
Footing	4-8 days	4-8 days	--	--	--
Abutment, Pier, & WW's	9-13 days	9-13 days	--	--	--
Substructure Curing	14 days	14 days	--	--	--
Framing	4-8 days	4-8 days	4-8 days	--	--
Deck Joints	3-6 days	3-6 days	3-6 days	3-6 days	3-6 days
Deck Forms	14-24 days	14-24 days	14-24 days	14-24 days	--
Shear Connectors	2-4 days	2-4 days	2-4 days	2-4 days	--
Deck	4-8 days	4-8 days	4-8 days	4-8 days	--
Deck Slab Curing	14 days	14 days	14 days	14 days	--
Header	1-2 days	1-2 days	1-2 days	1-2 days	--
Preformed Joint	2 days	2 days	2 days	2 days	2 days
Parapets	4 days	4 days	4 days	4 days	--
Railing/Fence	6 days	6 days	6 days	6 days	--
Sawcut Deck	1-2 days	1-2 days	1-2 days	1-2 days	1-2 days
Substructure Rehabilitation	--	--	9-18 days	3-6 days	--
Deck Repairs	--	--	--	--	12-24 days
LMC	--	--	--	--	4-8 days
LMC Curing	--	--	--	--	14 days
TOTAL	91-130 days	117-178 days	80-130 days	68-106 days	36-56 days

Allow 3 months (steel beams) and 4 months (concrete beams) for working drawing approval, fabrication and delivery. Designer shall verify anticipated timeframes prior to Final Submission.

**G. VI.e TABLE A (METRIC)
CONTRACTOR'S PRODUCTION RATES FOR ROADWAY ITEMS**

ITEM	Type 1 Construction	Type 2 Reconstruction	Type 3 Widening	Type 4 Resurfacing	Type 5 Intersections
Mobilization	10 Days*	10 Days*	5 Days	2 Days	2 Days
Clearing Site Including Stripping	1.6 hectares	1.6 hectares	1.6 hectares	N/A	N/A
Removal of Vertical Curb	N/A	300 LM	210 LM	120 LM	120 LM
Demolition of Buildings	1 Unit	1 Unit	1 Unit	N/A	N/A
Pest Control	10 Days	10 Days	10 Days	N/A	N/A
Asbestos Clean-up Resident and Small Commercial	4 Days	4 Days	4 Days	N/A	N/A
Large Commercial	10 Days	10 Days	10 Days		
Removal of Bituminous Concrete Overlay	N/A	2090 SM	2090 SM	2090 SM	250 SM
Roadway Excavation Embankment	2300 CM	765 CM	765 CM	N/A	N/A
Wet Excavation	1150 CM	270 CM	270 CM	N/A	N/A
Drainage Pipe Includes 1 Structure					
900 mm and Smaller	90 LM	45 LM	45 LM	N/A	45 LM
Larger than 900 mm	30 LM	18 LM	18 LM	N/A	18 LM
Reset Castings	N/A	5 Units	5 Units	5 Units	5 Units
Extension Frames and Rings	N/A	12 Units	12 Units	12 Units	12 Units
Subbase	270 CM	190 CM	115 CM	N/A	38 CM
Aggregate Base Course	270 CM	190 CM	115 CM	N/A	38 CM
Bituminous Concrete Base or Surface Course	1360 MGR	900 MGR	680 MGR	1180 MGR	225 MGR
Portland Cement Concrete Base or Surface Course	2090 SM	840 SM	625 SM	N/A	190 SM

Note: Production Rates are based on 8-hour working day per crew.

TYPE 1 = New construction, additions or major reconstruction of divided or undivided highways.

TYPE 2 = Reconstruction or upgrading existing highways.

TYPE 3 = Widening (less than one lane) and resurfacing existing highways.

TYPE 4 = Resurfacing existing highways with bituminous concrete.

TYPE 5 = Minor construction or reconstruction of street or highway intersections.

* = Use 20 days when \$20 million or higher.

**TABLE A (Con't) (METRIC)
CONTRACTOR'S PRODUCTION RATES FOR ROADWAY ITEMS**

ITEM	Type 1 Construction	Type 2 Reconstruction	Type 3 Widening	Type 4 Resurfacing	Type 5 Intersections
Bridge Approach Slabs or Transition Slabs	165 SM	165 SM	165 SM	N/A	N/A
Milling (up to 50 mm thick)	N/A	5000 SM	5000 SM	5000 SM	2090 SM
Concrete Barrier Curb	120 LM	105 LM	105 LM	75 LM	N/A
Concrete Vertical Curb	150 LM	120 LM	120 LM	90 LM	60 LM
Concrete Sidewalk	190 SM	150 SM	150 SM	125 SM	125 SM
Electrical Conduit	180 LM	120 LM	120 LM	45 LM	45 LM
Fiber Optic Conduit	300 LM	300 LM	300 LM	300 LM	N/A
Electrical Wire	365 LM	365 LM	365 LM	90 LM	90 LM
Lighting Standards	4 Unit	4 Unit	4 Unit	N/A	4 Unit
Traffic Signal Installation (1)	20 Days per Intersection	20 Days per Intersection	20 Days per Intersection	20 Days per Intersection	20 Days per Intersection
Reset Beam Guide Rail	N/A	150 LM	150 LM	120 LM	N/A
Beam Guide Rail	230 LM	230 LM	230 LM	150 LM	N/A
Chain Link Fence	120 LM	120 LM	120 LM	N/A	N/A
Overhead Sign Structure (2)	15 Days per Structure	15 Days per Structure	15 Days per Structure	15 Days per Structure	N/A
Landscaping, Turf	8,360 SM	8,360 SM	8,360 SM	N/A	N/A
Landscape, Planting (3)	Planting Season	Planting Season	Planting Season	Planting Season	N/A
Final Acceptance (4)	60 Calendar Days	60 Calendar Days	60 Calendar Days	30 Calendar Days	45 Calendar Days

Note: Production Rates are based on 8-hour working day per crew. (1) Manufacturing and delivery of steel traffic signal poles requires 4 months, aluminum lighting and traffic signal poles require 2 months and traffic signal controllers require 4 months.

(2) Allow 2 months for working drawing approval, fabrication and delivery.

(3) Planting seasons - from March 1 to May 1 and from August 15 to December 1.

(4) Final Acceptance shall be 15 calendar days for resurfacing projects \$2 million or less.

**G. VI.f TABLE B (METRIC)
CONTRACTOR'S PRODUCTION RATES FOR BRIDGE ITEMS**

ITEM	Type 1 Construction	Type 2 Reconstruction	Type 3 Superstructure	Type 4 Deck	Type 5 Overlay
Cofferdams	20 days	20 days	N/A	N/A	N/A
Retaining Walls (1,3) (Cast-in-Place)	20 days/30 m	20 days/30 m	N/A	N/A	N/A
Box Culverts (Cast-in-Place)	10 days/10 m	10 days/10 m	N/A	N/A	N/A
Box Culverts (2) (Precast)	5 days/10 m	5 days/10 m	N/A	N/A	N/A

Notes:

- Production Rates are based on 8-hour working day per crew.
- For two bridges add 50%, for each additional bridge add 25%.
- For Stage Construction, consider each stage to be a separate bridge.
- For bridges over water or railroads add 30 days, except for Type 5 for which no adjustment is necessary.
- Production rates include the time required for concrete curing.

- (1) Add 5 days per 30 meters if temporary sheeting is required.
- (2) Includes excavation and placing, allow 3-4 months for working drawing approval, fabrication and delivery.
- (3) Use for Reinforced Earth, Double Wall and Anchored Walls.

Type 1 = New Construction on new alignment.

Type 2 = Remove existing bridge and construct new bridge at same location.

Type 3 = Replace deck and beams including minor substructure repair.

Type 4 = Replace deck.

Type 5 = Deck patching and LMC overlay (subtract 10 days if overlay is bituminous concrete).

G. VI.g TABLE C (METRIC)
Bridge Item
Contractor Production Rates
One Span Bridge (12 to 30 meter Range)

BRIDGE TYPE/BRIDGE ITEM	TYPE 1	2	3	4	5
	NEW ON NEW ALIGNMENT	NEW ON SAME ALIGNMENT	SUPERSTRUCTURE REPLACEMENT	DECK REPLACEMENT	B, C & LMC
Demolition	--	16-28 days	8-16 days	7-14 days	--
Foundation Excavation	2-4 days	2-4 days	--	--	--
Piles	4-6 days	4-6 days	--	--	--
Footing	2-4 days	2-4 days	--	--	--
Abutment, Pier, & WW's	6-8 days	6-8 days	--	--	--
Substructure Curing	14 days	14 days	--	--	--
Framing	2-4 days	2-4 days	2-4 days	--	--
Deck Joints	2-4 days	2-4 days	2-4 days	2-4 days	2-4 days
Deck Forms	7-12 days	7-12 days	7-12 days	7-12 days	--
Shear Connectors	1-2 days	1-2 days	1-2 days	1-2 days	--
Deck	2-4 days	2-4 days	2-4 days	2-4 days	--
Deck Slab Curing	14 days	14 days	14 days	14 days	--
Header	1-2 days	1-2 days	1-2 days	1-2 days	--
Parapets	2 days	2 days	2 days	2 days	--
Preformed Joint	1 day	1 day	1 day	1 day	1 day
Railing/Fence	3 days	3 days	3 days	3 days	--
Sawcut Deck	1 day	1 day	1 day	1 day	1 day
Substructure Rehabilitation	--	--	6-12 days	2-4 days	--
Deck Repairs	--	--	--	--	6-12 days
LMC	--	--	--	--	2-4 days
LMC Curing	--	--	--	--	14 days
TOTAL	64-85 days	80-113 days	50-77 days	43-63 days	26-36 days

Allow 2 months (steel beams) and 3 months (concrete beams) for working drawing approval, fabrication and delivery. Designer shall verify anticipated timeframes prior to Final Submission.

G. VI.h TABLE D (METRIC)
Bridge Item
Contractor Production Rates
Two Span Bridge (55 to 60 meter Range)

BRIDGE TYPE/BRIDGE ITEM	TYPE 1	2	3	4	5
	NEW ON NEW ALIGNMENT	NEW ON SAME ALIGNMENT	SUPERSTRUCTURE REPLACEMENT	DECK REPLACEMENT	B, C & LMC
Demolition	--	26-48 days	16-32 days	14-28 days	--
Foundation Excavation	3-5 days	3-5 days	--	--	--
Piles	6-10 days	6-10 days	--	--	--
Footing	4-8 days	4-8 days	--	--	--
Abutment, Pier, & WW's	9-13 days	9-13 days	--	--	--
Substructure Curing	14 days	14 days	--	--	--
Framing	4-8 days	4-8 days	4-8 days	--	--
Deck Joints	3-6 days	3-6 days	3-6 days	3-6 days	3-6 days
Deck Forms	14-24 days	14-24 days	14-24 days	14-24 days	--
Shear Connectors	2-4 days	2-4 days	2-4 days	2-4 days	--
Deck	4-8 days	4-8 days	4-8 days	4-8 days	--
Deck Slab Curing	14 days	14 days	14 days	14 days	--
Header	1-2 days	1-2 days	1-2 days	1-2 days	--
Preformed Joint	2 days	2 days	2 days	2 days	2 days
Parapets	4 days	4 days	4 days	4 days	--
Railing/Fence	6 days	6 days	6 days	6 days	--
Sawcut Deck	1-2 days	1-2 days	1-2 days	1-2 days	1-2 days
Substructure Rehabilitation	--	--	9-18 days	3-6 days	--
Deck Repairs	--	--	--	--	12-24 days
LMC	--	--	--	--	4-8 days
LMC Curing	--	--	--	--	14 days
TOTAL	91-130 days	117-178 days	80-130 days	68-106 days	36-56 days

Allow 3 months (steel beams) and 4 months (concrete beams) for working drawing approval, fabrication and delivery. Designer shall verify anticipated timeframes prior to Final Submission.

G. VII. Acceleration of Construction Schedules

To reduce construction time to lessen the impact on the traveling public and the community where the highway construction is scheduled, the following methods may be considered:

1. Increased Production Rates
2. Incentive/Disincentive (I/D)
3. A+B Bidding
4. Lane Rental - Note: This specification is not currently available. This specification needs to be developed and processed for DAG approval.

The acceleration of project schedules may be warranted when:

- There is high road user cost as calculated in accordance with the NJDOT Road User Cost Manual resulting from delays or diversions from construction activity.
- There are seasonal requirements on highways leading to points of recreational interest, resort areas, vacation areas, regional retail centers, major public facilities, etc.
- The work involves significant impact on the community such as the need for night work, detours, and disruption to public transit, etc.
- The project is of an emergency nature or is required to meet a critical safety need.
- It is essential the project be completed to allow for a specific opening date or construction of adjacent projects.
- There is a significant reduction in user delays after construction is completed.
- The construction schedule can be reduced to the nearest full construction season.

In addition, the following conditions must be met if acceleration of the project schedule is to be considered:

- R.O.W. availability, utility agreements and permits will be available/completed by the advertisement date.
- Sufficient project funding is available on multiyear funded projects.
- Railroad work is not involved.
- The benefits of accelerating the project outweigh the additional construction costs.
- Local community involvement

When accelerating project schedules, in addition to the progress schedule for normal times and rates, a second progress schedule shall be prepared reflecting the accelerated schedule and rates that shows the work being achieved by the accelerated completion date.

G. VII. a. Increased Production Rates

To accelerate up the construction process, increased production rates may be used where I/D or A+B project delivery methods would not be applicable.

Increased production rates may require the use of multiple crews, night work, and/or overtime, which may include an around-the-clock work schedule. If longer than 8-hour day and or accelerated production rates are used, an explanation shall be provided in the submission. In addition, the increased cost shall be reflected in the Construction Cost Estimate.

A production rate of **1.20** times the Designer's established standard production rate will be utilized to establish the completion date. The designer shall analyze the staging and work areas of the project to ensure the increased production rates do not apply to confine areas where the rate would not be achievable.

G. VII. b. Incentive / Disincentive (I/D)

I/D provisions for early completion of construction projects are intended to motivate the contractor to complete the work on or ahead of schedule. They compensate the contractor a daily amount for completing the work ahead of the I/D completion date or assess a daily amount for finishing later than the I/D completion date.

The daily amount of I/D will be calculated for each project.

The I/D provisions apply to major highway or bridge resurfacing, rehabilitation, reconstruction and restoration (4R) projects on existing alignment with:

- Prolonged reduction in the number of available lanes on freeways or high volume land service roadways.
- A prerequisite to the use of some other project, i.e., to remove a serious bottleneck or to close a gap.
- Use of long detours.
- A need to provide service to some other major traffic generator.
- A major bridge temporary taken out of service.
- Safety concerns.
- Severe impacts on local communities or businesses.
- A useful part of the project which can be completed well before the rest of the work and provides a significant benefit to the public.

Examples of Some Typical Project Types Include:

- Roadway reconstruction causing lane reductions, lane closures or two-lane two-way traffic on Interstate highways and freeways.
- Major interchange construction.
- Major bridge or tunnel construction.
- Overnight lane closures.

The use of I/D provisions may also be considered for projects with new alignment.

Selection Criteria

Selective use shall be made of I/D provisions. In addition to the warrants for accelerating projects that were noted previously, the following conditions must also be met to permit the use of I/D provisions in the contract:

- Utility work not being performed by the contractor shall be limited to only work that will not interfere with the I/D phase(s) of the contract.
- The I/D amount results in a favorable work zone cost/benefit ratio to the traveling public. The benefit to the highway user equals the I/D amount, and this amount is enough to motivate a contractor to accelerate.
- The construction schedule is determined by production rates shown in Tables G.IV A, G.V B, G.VI C and G.VII D. *
- The project shall not have any anticipated changes of plan.
- The contract documents must clearly indicate any unusual conditions or restrictions.
- The contract must clearly define what constitutes the start and completion of the I/D phase(s).
- The work to be completed under the I/D provisions must be clearly defined.
- Review and approval of field changes or working drawings must be promptly provided at all times that I/D work is in progress.

* A production rate of **1.33** times the Designer's established standard production rate will be utilized to establish the timesaving that can be achieved with I/D provisions. The designer shall analyze the staging and work areas of the project to ensure that the increased production rates do not apply to confine areas where the rate would not be achievable.

G. VII. c. A + B Bidding

A+B bidding is a cost-plus-time bidding procedure. This bidding procedure selects the low bidder based on a monetary combination of the contract bid items (A) and the time (B) needed to complete the project or a critical portion of the project.

Formula: Bid amount for evaluation = $A + (B \times RUC)$

Where: A = bidder's estimate of contract bid items (\$)
B = bidder's estimate of time (days)
RUC = work zone road user costs (\$/day)

The award is based on the lowest combined bid using the above formula. The contract amount for payment purposes is the "A" amount only.

A+B bidding may be considered on a wide variety of paving or bridge projects on existing alignments. The project types are similar to projects using I/D provisions. Applications range from major urban interstate and freeway rehabilitation projects with high average daily traffic (ADT) to lower volume two-lane rural highway resurfacing or bridge rehabilitation projects.

Selection Criteria

A+B bidding can be selected for projects when:

- Traffic restrictions, lane closures, or detours result in high work zone road user costs. The monetary benefit to the highway user equals or exceeds the contractor's costs to finish early.
- Safety concerns, or significant impacts to the local community or economy during construction warrant expediting the project.
- Traffic control phasing can be structured to maximize a contractor's ability to reduce the duration of construction.
- The project has no design uncertainties, utility work, or right-of-way issues, which may impact the bid letting date or the projects critical schedule.
- It is public interest to complete the project as soon as possible and the agency will seek the contractor's expertise to facilitate an earlier completion.
- There is a significant impact on access to local businesses.

Other Conditions

- Project can be completed within one construction season with accelerated construction.
- A project start date shall be included in the contract specifications.

A production rate of **1.25** times the Designer's established standard production rate will be utilized to establish a construction duration comparison with and without A + B bidding. The designer shall analyze the staging and work areas of the project to ensure that the increased production rates do not apply to confine areas where the rate would not be achievable.

G. VII. d. Lane Rental

Note: This specification is not currently available. This specification needs to be developed and processed for DAG approval.

Lane rental provisions assesses the contractor daily or hourly rental fees for each lane, shoulder, or combination of lanes and shoulders taken out-of-service during construction of a project to minimize the time that roadway restrictions impact traffic flow. The rental fee is based on work zone road user costs and daily costs incurred by the Department.

Lane rental applies to the critical portion or portions of a project where traffic flow is impacted. Lane rental is particularly applicable to projects where the contractor can adjust or structure the traffic control plan to reduce lane closure durations, or to take lanes out of service during periods of the day when impacts to traffic are minimal.

Typical project types include:

- Major roadway, bridge, or interchange 4R projects with high ADT and traffic restrictions or lane closures.
- Projects or portions of projects involving temporary lane, ramp, or bridge closures.
- Emergency repair work.

Selection Criteria

Lane rental may be considered for projects when one or more of the following conditions exist:

- Traffic restrictions or lane closures result in high work zone road user costs.
- The use of alternate routes or off-site detours is impractical.
- The traffic control plan allows the contractor flexibility in scheduling work to minimize the impact of lane closures.
- The Department seeks contractor's expertise to minimize the time that lanes are out of service.
- The project has no design uncertainties, utility work, or right-of-way issues, which may impact the project schedule.
- The benefit in terms of the reduced impact to the highway user is greater than the additional cost to minimize lane closures.

G. VIII. Designer Narrative

The Designer shall submit a written narrative with each submission of a Progress Schedule. Included in this narrative shall be:

- Anticipated production rates
- Anticipated workforce (i.e. number of crews, size, crew type etc.)
- Anticipated work during the Winter Season (December through March inclusive) and the number of workdays for Bridge and Roadwork.
- Permit requirements
- Utility requirements
- ROW requirements
- Community commitments
- Lead time for special materials
- Detours and anticipated timeframe
- Any critical milestones (i.e. road/ramp openings, critical stages etc.)
- Any anticipated problems meeting the schedule (ROW, Utilities etc.)
- Description of any acceleration applied to the project's schedule
- The number of working days for each operation as shown in Appendix D. This is only for Federal participating projects.

H. Contractor Procedure

H.1 Contractor Standard Naming of Projects

For projects under 1 year in duration, the contractor shall assign a four-character file name.

The first three characters will be the project identifier. The last digit will be as follows:

0 will be the working schedule

1 - Baseline 1

2 - Baseline 2 etc.

A - First update

B - Second update etc.

For projects over 1 year in duration, the contractor shall assign a four-character file name.

The first two characters will be the project identifier. The last two digits will be as follows:

00 will be the working schedule

01 - Baseline 1

02 - Baseline 2 etc.

AA - First update

AB - Second update etc.

BA - 27th update

Working Schedule = XXX0

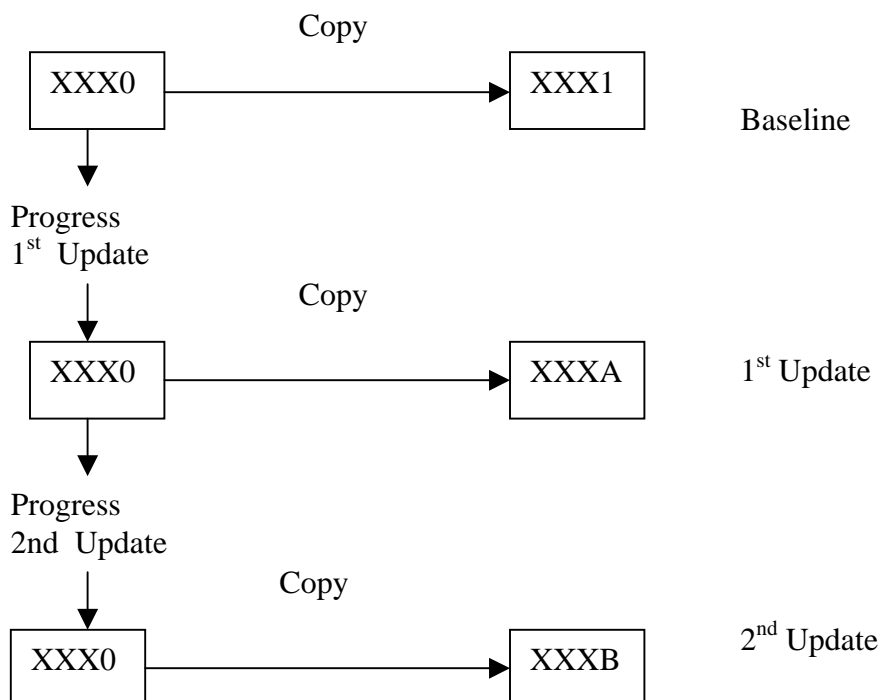

Appendix A. Definitions

Activity - An element of work performed during the course of a project. An activity normally has an expected duration, an expected cost, and expected resource requirements. Activities are often subdivided into task.

Actual Start Date- The point in time that work actually started on an activity

Actual Finish Date- The point in time that work actually ended on an activity. (Note: in some applications areas, the activity is considered “finished” when work is “substantially complete.”)

Baseline Schedule - The original plan against which your progress is measured. The baseline represents the original plan at the onset of the project of what you expect to happen. The baseline is saved once the schedule is presented to the stakeholders and other interested parties, and has been agreed to by all parties.

Critical Path – In a project network diagram, the series of activities, which determines the earliest completion of the project. The critical path will generally change from time to time as activities are completed ahead of or behind schedule. Although normally calculated for the entire project, the critical path can also be determined for a milestone or subproject. The critical path is usually defined as those activities with float less than or equal to a specified value, often zero.

Critical Path Method (CPM) – A network analysis technique used to predict duration by analyzing which sequence of activities (which path) has the least amount of scheduling flexibility (the least amount of float). Early dates are calculated by means of a forward pass using a specified start date. Late dates are calculated by means of a backward pass starting from a specified completion date (usually the forward pass’s calculated project early finish date).

Deliverable – Any measurable, tangible, verifiable outcome, result, or item that must be produced to complete a project or part of a project. Often used more narrowly in reference to an external deliverable, this is a deliverable that is subject to approval by the project sponsor or customer.

Duration – The number of working days (not including holidays or other non-working periods) to complete an activity or other project element. Sometimes incorrectly equated with elapsed time.

Early Dates - Earliest an activity can start or finish based upon logic and durations. Calculated by the computer during the forward pass.

Fragnet – A subdivision of a project network diagram usually representing some portion of project

Free Float - The amount an activity can slip *without delaying the next activity*. This could be important for resource management.

Lane Occupancy – When a Contractor occupies a lane(s) in proceeding with their work. The Contractor shall pay a Lane Occupancy Charge (per direction) for the period of time a lane is unavailable to the traveling public beyond the allowable lane closure time limits.

Late Dates – “Drop dead dates”. The latest and activity can start or finish without delaying the day of completion. Calculated by the computer during the backward pass.

Milestone - A significant event in the project, usually the completion of a major deliverable or stage.

Predecessor -Activities that are required for the start of a given activity is know as predecessor. Predecessors are added using the Detailed Predecessor Form. Every activity must have a predecessor except project start.

Preliminary Schedule – Initial schedule prior to the baseline schedule reflecting how the contractor plans to proceed with constructing a project.

Recovery Plan – Contractor’s plan to bring the project back on schedule. This includes a revised CPM schedule and additional manpower and equipment.

Relationships Between Activities

Finish to Start - The successor activity can begin only when the current activity completes

Finish to Finish – The finish of the successor activity depends on the finish of the current activity

Start to Start – The start of the successor activity depends on the start of the current activity

Start to Finish – The successor activity cannot finish until the current activity starts

Remaining Duration – The time needed to complete an activity.

Successor -Activities that follow a given activity are known as successors. Successors are added using the Detailed Successor Form. Every activity must have a successor except project complete.

Total Float - The amount a activity may be delayed from its early start without delaying the day of completion. Float is a mathematical calculation and can change as the project progresses and changes are made to the project plan. Also called slack and path float.

Updated Schedule – A schedule that truly reflects the current means and method how the project is progressing.

Work Breakdown Structure (WBS) - A deliverable-oriented grouping of project elements, which organizes and defines the total scope of the project. Each descending level represents an increasingly detailed definition of a project component.

Working Schedule – A schedule utilized for duration of a project for creation of the baseline schedule and updates.

Work Package - A deliverable at the lowest level of the work breakdown structure. A work package contains activities.

Appendix B. Time Impact Evaluation Form

TIME IMPACT EVALUATION (TIE)

PROJECT: _____

TIE # _____

PREPARED BY: _____

DATE: _____

DESCRIPTION:

ACTIVITIES AFFECTED:

TYPE OF IMPACT:

INCREASED DURATION: _____

AMOUNT: _____

DELAYED DATE/SUSPENSION OF WORK: _____

FRAGNET:

EVALUATION/RESPONSIBILITY

Appendix C. Utility Companies by Area

Utility Company(ies)	Region	County(ies)	Remarks (Area)
Public Service <u>Electric</u> & Gas (Electric)	Palisades	Bergen	All
		Hudson	All
	Metropolitan	Passaic	Eastern Half
		Essex	All
Central	Union Somerset Middlesex	Eastern Three Quarters Northern Half Western Half	
Southern	Mercer Burlington Camden Gloucester	Central Half Western Quarter Western Half NorthWestern Corner Only	
Jersey Central Power & Light d/b/a GPU Energy	North	Sussex	All
		Warren	All
		Morris	All
		Hunterdon Somerset	All Northern Quarter
	South	Middlesex Monmouth	Eastern Half All
		Ocean Mercer Burlington	Northern Three Quarters Western Quarter North East Corner
Rockland Electric	N/A	Passaic	All
		Bergen	North Western Corner Only
Atlantic City Electric d/b/a Connective		Cape May	All
		Salem	All
		Cumberland	All
		Camden	Eastern half
		Burlington	Southern Half
		Gloucester	Except North Western Corner
Ocean	Southern Quarter		
Atlantic	All		
City of Vineland Electric Co	N/A	N/A	City of Vineland

Public Service Electric & Gas (Gas)	North	Bergen	All
		Passaic	All
		Hudson	All
		Essex	All
		Union	Western Quarter
		Morris	Southern Half
		Somerset	All
	Hunterdon	Eastern Quarter	
	South	Middlesex	Southern Three Quarters
		Mercer	Except Western Corner
		Monmouth	Western Quarter
		Burlington	Northern Half
		Camden	Western Third
		Gloucester	North Western Corner
Ocean		North Western Corner	
Elizabethtown Gas Co		Sussex	All
		Warren	All
		Hunterdon	Western Three Quarters
		Mercer	Western Quarter
		Morris	Western Quarter
		Union	Eastern Three Quarter
		Middlesex	Eastern Quarter
New Jersey Natural Gas Co	North	Morris	Eastern Three Quarters
	South	Monmouth	Eastern Three Quarters
		Ocean Burlington	Except North Western Corner South Eastern Corner Only
South Jersey Gas	N/A	Burlington	Central Quarter
		Camden	Eastern Two Thirds
		Gloucester	Except North Western Corner
		Salem	All
		Cumberland	All
		Atlantic	All
		Cape May	All
United Water	N/A	Bergen	All
		Hudson	All

New Jersey American Water	N/A	Atlantic Cape May Gloucester Camden Burlington Monmouth Essex Union Somerset Morris Warren	Eastern Quarter Upper & Middle Townships Southwest Corner Central One Third Southwest Corner Eastern Half Southwest Corner Northwest Corner Northern Most Edge Southern Most Edge Southern One Third
Middlesex Water	N/A	Middlesex	Northern Half
Elizabethtown Water	N/A	Hunterdon Mercer Middlesex Morris Somerset Union Burlington Ocean	Eastern One Third Northern Central Northwest & Southwest Corner Chester Township All All Northern Central Plumsted Township
Verizon Communications	N/A	State Wide	All
AT&T	N/A	State Wide	All
Sprint d/b/a United Telephone Co of NJ	N/A	Sussex Warren Morris Hunterdon Somerset	All Northern Half Western Half Northern Half Northern Half

APPENDIX D. NJDOT Request for Trainees Memo

9.5

Job Code # :

BRITT-DJH-08/18/00

Page 1 of 3

NEW JERSEY DEPARTMENT OF TRANSPORTATION
MEMORANDUM

THIS FORM IS FOR INFORMATION ONLY: CONTACT PROGRAM SUPPORT SERVICES FOR THE MOST CURRENT FORM.

TO:

Division of Civil Rights

FROM:

Cost Estimating

Program Support Services

DATE:

PHONE: 530-5630

SUBJECT: Route _____ Section
Federal. Project No. _____ UPC No.

The Estimate should be considered confidential and should only be made available to Department personnel on a need to know basis.

Based on the following criteria, we are asking that you provide this Bureau with the number of Trainees and Man-Hours on the above captioned Project.

Type of Work: _____ (From Key Sheet)

Length of Project: _____ (Miles / Meters)

Estimated Duration: _____ (Actual Construction working days less acceptance)

Estimated Cost: _____ (Phase 4/Final Estimate)

The work to be performed on this Project consists of the following: _____

We are attaching operations, Journeyman Classifications and the number of working days for each Classification. Also attached is a Final phase Engineer's Estimate.

DIVISION OF CIVIL RIGHTS

THE NUMBER OF TRAINING POSITIONS WILL BE _____, WHERE FEASIBLE,
CONSISTING OF AT LEAST _____ APPRENTICES AND _____ APPRENTICE
GRADUATES OF THE P.A.P. AND/OR TRAINEES. HOURS =

BY: _____ DATE: _____
AFFIRMATIVE ACTION SPECIALIST I, CIVIL RIGHTS

cc: As required.

JOURNEYMAN CLASSIFICATIONS

<u>OPERATIONS</u>	<u>CLASSIFICATIONS</u>	<u>NUMBER IN EACH CLASS</u>	<u>NUMBER OF WORKING DAYS</u>	
Construction Layout:	Survey Party Members	3		
Grading:	Operating Engineers	2 to 6		
	Type 1 use 6			
	Type 2 use 4 or 5			
	Type 3 use 3 or 4			
	Type 4,5,6 & 7 use 2 or 3			
	Oilers	1		
	Grade Foreman	1		
	Truck Drivers	1 to 5		
	Type 1 or 2 use 5			
	Type 3 use 3 or 4			
Drainage: (per pipe crew)	Type 4,5,6 & 7 use 1 to 3			
	Drill Operators (if rock)	1		
	Blasters (if rock)	1		
	Grade Foreman	1		
	Operating Engineers	1		
	Oilers	1		
	Pipe Layers	2		
	Bricklayers	1		
	Curb and other miscellaneous conc.: (per crew)	Form Setters	1	
		Concrete Finishers	2	
Bituminous Paving:	Operating Engineers	3		
	Oilers	1		
	Screedman, Foreman, Rakers	2		
Concrete Paving:	Operating Engineers	4		
	Oilers	1		
	Concrete Finishers	6		
	Grade Foreman	1		
	Form Setters	2		
	Ironworkers	2		

JOURNEYMAN CLASSIFICATIONS

<u>OPERATIONS</u>	<u>CLASSIFICATIONS</u>	<u>NUMBER IN EACH CLASS</u>	<u>NUMBER OF WORKING DAYS</u>	
Bridge and Large Walls:	Piledriverman or dockbuilders (each rig if piles)	5		
	Operating Engineers (each rig if piles)	2		
	Oilers (piledriver)	1		
	Operating Engineers	3		
	Oilers	1		
	Carpenters	10		
	Type 1 use 10			
	Type 2 use 8 to 10			
	Type 3 use 6 to 8			
	Type 4,5,6 & 7 use 3 to 6			
	Ironworkers	5		
	Type 1 use 5			
	Type 2 use 4			
	Type 3 use 3			
	Type 4,5,6 & 7 use 2			
	Concrete Finishers	3		
	Electricians	2		
	Painters	3		
	Landscape Work:	Operating Engineers	1	
		Oilers	1	
Landscape Foreman		1		
Electrical Work:	Operating Engineers	1		
	Electricians	4		
	Electrician Foreman	1		
Signs:	Operating Engineers	1		
	Oilers	1		
	Ironworkers	1		
	Carpenters	1		
Guide Rail:	Operating Engineers	1		
	Oilers	1		
	Ironworkers	1		

APPENDIX E.
General Workday Chart (Contract Time Determination only)

Month	Roadwork (WD)	Bridgework (WD)
January	0	10
February	0	10
March	10	10
April	15	15
May	20	20
June	20	20
July	20	20
August	20	20
September	20	20
October	15	15
November	15	15
December	10	10

APPENDIX F.

Procedure for using the Construction Scheduling Template containing Standard Coding for Designers and Contractors

1. The file is a “Back Up” of a Template to be utilized by Designers and Contractors. The file can be accessed utilizing Primavera Project Planner P3 or Primavera SureTrax.
2. The project is to be “Restored” to a suitable folder within your computer system from which you will create the schedule. Naming and coding of the project shall be in accordance with the Capital Program Management Construction Scheduling Standard Coding and Procedures for Designers and Contractors.
3. Contained in this Template are the following:
Work Breakdown Structure (WBS) (**Each activity** in the schedule shall be assigned to the appropriate WBS element)
 - Milestone Activities:
 - ✓ Milestones M100, M200, M300, M500, M900, M950 shall be utilized for every project. M700 shall be utilized if an interim date will be or is part of the Contract (EXPAND FOR OTHER MILESTONES).
 - ✓ If a Milestone activity will not be or is not part of the Contract – it shall be deleted for that project.
 - ✓ Milestone Activity numbers and Descriptions are not to be changed except for Intermediate Milestones for Stages, Interim Completion dates and ROW availability dates.
 - Construction
 - ✓ Construction is broken down by stage and then by area
 - ✓ Stages were developed using 1, 2, 3 etc then further broken down 1A, 1B, 1C etc. (i.e. Use Stage 1 for Stage 1 Activities, Use Stage1A for Stage 1A activities etc.)
 - ✓ Areas are user defined and coding shall be utilized as shown in the Capital Program Management Construction Scheduling Standard Coding and Procedures for Designers and Contractors.
 - Procurement: Procurement WBS is utilized for **all** submission and procurement activities.
 - Design (Design/Build only)
 - ✓ This can be deleted if it is not a Design/Build project
4. Activities: Each activity shall begin with an alpha character. The character is user assigned.
 - Each activity shall be assigned (as a minimum) a WBS structure, responsibility, project area, class of work, type of work and calendar.
5. Calendars: The following calendars are given in the template:
 - State Business Days
 - Deciduous trees
 - Broad leaf trees
 - 7 Day work week

They are not to be changed in any way or deleted.

Calendars can be added as determined by the user.

NOTE: If Sure Trax is software utilized, the project shall be saved as a Primavera P3 file NOT
Sure Trax

**Any questions or problems with the template shall be directed to the Bureau of Quality
Management Services, Construction Scheduling and Assessment Section.**